

Perfiles y guías en aluminio

CARACTERÍSTICAS

MEDIDAS	
LÍNEA MÁXIMA	ALTURA MÁXIMA
2400	2500

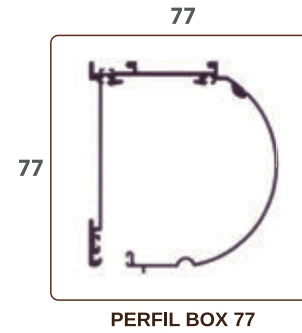

PERFIL BOX 77

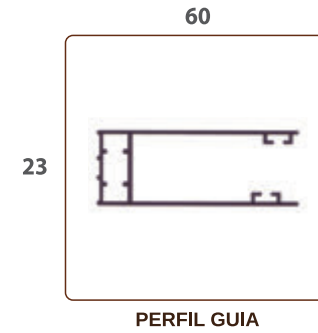

PERFIL GUIA



Tapas laterales en plástico

INSTALACIÓN

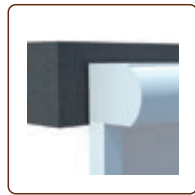

FRONTAL

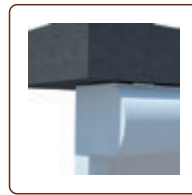

TECHO



ENTRE PAREDES
(Fijación por las Guías)

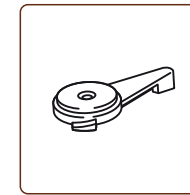

SOPORTE TECHO
(Standard)

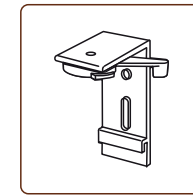

SOPORTE PARED

ACCIONAMIENTO



MANUAL
(Cadeneta)



MOTOR
(Rápido + Silencioso)



MOTOR
(Batería + Silencioso)



MOTOR
(Solar)

OPCIONES



SOPORTES A PARED

CERTIFICACIONES



LACADO



INOX
TORNILLERÍA

COLORES



Blanco



Carta RAL



Tejidos con opacidades de 1%, 3%, 5% y Blackout

MÁS INFORMACIÓN
APP



www.mecanotoldo.com

BOX-77  90